



# Insulated Structures

*Efficiency At Work*

## SQUARE GLASS - PIE



Standard Specifications
• 2 x Sticky Heat LED Lit Glass Shelves
• Linear Front Bar
• Rear Sliders
• Powder Coated Cladding
• Electronic Temp Controller

Optional Specifications
• 20mm Glass Patch Ends
• Solid Patch Ends
• Humidifier Insert
• Cladding Options: Refer to Cladding Details Document (Available on Request)

*Leaders in world class innovation for bespoke end to end energy efficient refrigeration solutions*



Insulated Structures  
*Efficiency At Work*



# Insulated Structures

*Efficiency At Work*

## SQUARE GLASS - PIE:

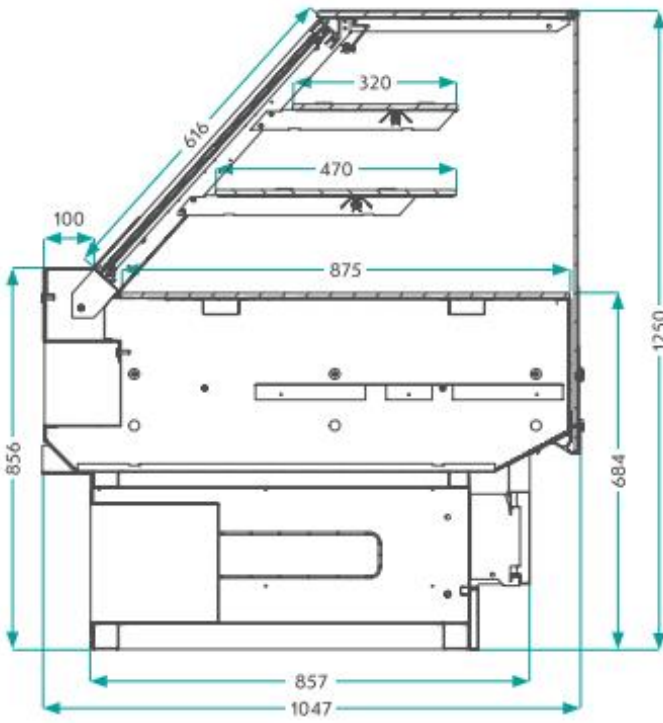

SIDE SECTION VIEW

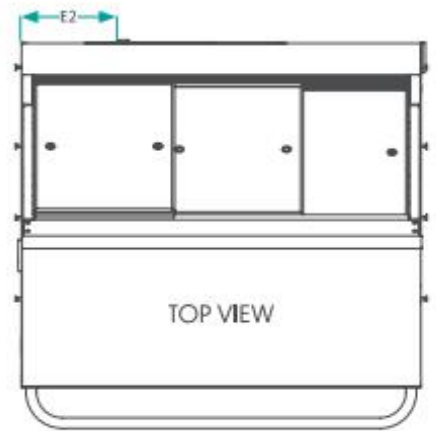

TOP VIEW

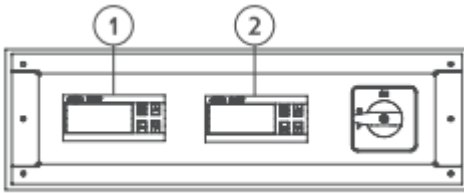

Controller Requirements		
Number	Control Temp Settings	Shelves
1	75°C	Bottom Pan
2	75°C	Shelf x 2

Physical Properties					Electrical Specifications				
Size	Length (m)	TDA (m <sup>2</sup> )	E1	E2	Sticky Heat	Case LED	Shelf LED	Canopy LED	Shelf LED
3ft	0.915	0.91	-	90mm	2x325W+2x480W	1x10W	2x10W	1x16W = 16W	2x12W = 24W
4ft	1.220	1.23	-	100mm	2x435W+2x643W	1x16W	2x16W	2x25W = 25W	2x20W = 40W
6ft	1.830	1.87	-	160mm	2x660W+2x1015W	1x25W	1x25W	2x16W = 32W	4x12W = 48W

*Leaders in world class innovation for bespoke end to end energy efficient refrigeration solutions*



Insulated Structures  
*Efficiency At Work*